





Point Level Detector (PLD) Installation

General

The Point Level Detector is designed to detect liquid level in plastic containers. The desired detection point will be determined by the mounting location of the sensor on the container. When the liquid level reaches the mid-point of the sensor, a logic high output signal will be present.

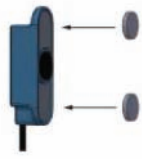
Each Point Level Detector is supplied with a set of attachment pads. These attachment pads are to be fastened to the container and mate with the permanent attachment pads on the detector body as shown below.

Mounting Procedure

			
1) Attach supplied mounting pads to sensor body pads and pressing into place.	2) Peel adhesive backing off of the mounting pads. Press firmly on to the container. Note that center of detector will be the detection point.	3) Remove detector from container. The mounting pads should remain on the container so that the detector may be reattached to the container anytime.	4) Reattach the detector to the container as necessary for usage.

Electrical Connections

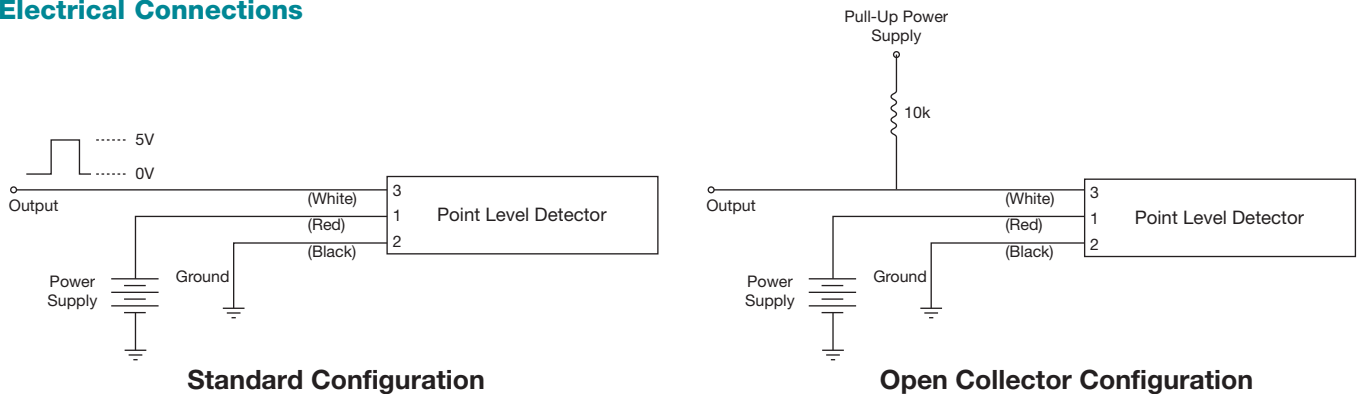

OPTIONS

LED: will illuminate during liquid detect

Open Collector: Output activate during liquid detect

Mounting Consideration

