

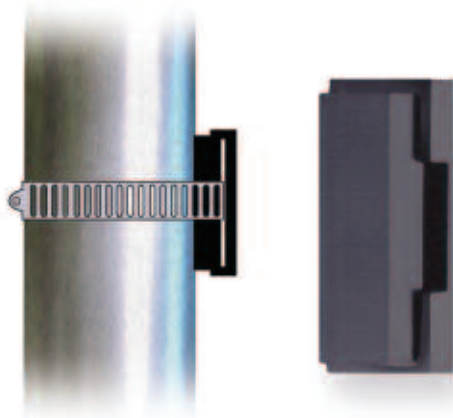

**The Introtek Advantage** provides products of unsurpassed quality, functionality and dependability that are manufactured to the highest medical device standards and backed by a three-year warranty.

## BDS Strap-On Ultrasonic Sensor

*A pulsed ultrasonic strap-on sensor designed for bubble detection and point liquid level sensing.*



**I**ntrotek's BDS Sensors are designed to work well with a wide range of tubing materials and sizes. When utilized with Introtek's circuitry they provide the most reliable strap-on bubble detection. BDS sensors are typically used on tubing larger than one inch and can detect point level on containers up to four feet in diameter.

### TECHNOLOGY

Introtek's ultrasonic air bubble detectors and liquid level sensors utilize the characteristics of high-frequency acoustic energy to monitor tubing or vessels for the presence of air, air bubbles, foam, or liquid. A sensor containing piezoelectric crystals is placed in direct contact with the desired point of detection. Introtek's air detection sensors and electronics emit pulses of ultrasonic energy, which are sent through tubing and normally received within a specified "window" of time. If air becomes present, the ultrasonic signal does not arrive within this "window" of time and a warning or dry signal is immediately transmitted.

### HIGHLIGHTS

- ◆ BDS Strap-On sensor for larger diameter tubing and liquid level applications.
- ◆ Non-invasive technology does not contact the fluid or require a break in the tubing.
- ◆ Low cost, premium performance.
- ◆ Wide range of sizes and mounting options.
- ◆ Fastest air detection circuitry available.
- ◆ Not affected by fluid color or tubing material.
- ◆ High EMI and RFI noise immunity.
- ◆ Custom manufactured systems for OEM applications available.

### INTROTEK'S CERTIFICATIONS



### APPLICATIONS

- ◆ Air bubble, air-in-line and liquid level sensing
- ◆ Patient-connected medical devices, including:
  - Apheresis
  - Auto-transfusion
  - Infusion pumps
  - Perfusion-based "life support" devices
  - Heart-lung bypass
  - Dialysis
  - Cardiac assist pumps
- ◆ Immunoassay and diagnostic equipment
- ◆ Liquid and chemical dispensing
- ◆ Blood processing equipment

# BDS Strap-On Ultrasonic Sensor

## FUNCTIONAL SPECIFICATIONS

### Sensor:

The BDS Sensor is cast of a rigid epoxy resin and works well with rigid or less pliable tubing. It can be machined to fit the face of storage containers up to four feet in diameter.

The strap-on style sensor must be sized to the exact tubing outside dimensions. It may be necessary to provide a tubing sample in order to provide an air detection system that meets application specifications.

Strap-on style sensors work well as a dry-line or point liquid level sensor for many types of metal tubing and containers one inch in diameter or above. Due to the widely varying acoustic ringing characteristics of metal tubing, we will require a tubing sample for all applications.

### Application:

Since the strap-on style sensors are a rigid epoxy resin, and are typically used with a rigid, less pliable tubing and containers, it may be necessary to utilize the aide of a coupling agent to improve acoustic coupling. Typical coupling agents may include petroleum jelly and silicon grease.

### Liquid:

Air will be detected in almost any liquid.

### Calibration:

No field calibration is required.

### Temperature limits:

Operating: +41° to +140° F (+5° to +60° C)

Storage: -4° to +185° F (-20° to +85° C)

### Humidity:

0 to 95% Non-Condensing

### Electronics:

Utilizes remote circuitry.

inches (mm)

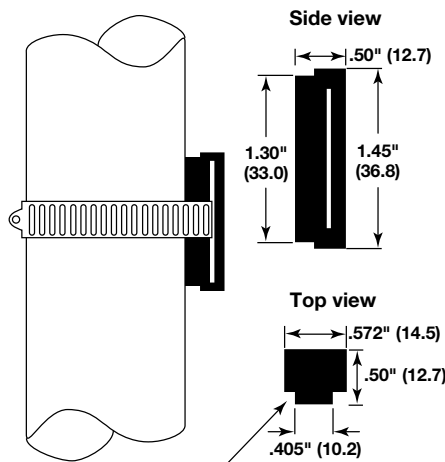

NOTE: A curve is machined to the pipe diameter.

Non-invasive strap-on sensor

## VALIDATION TESTING

The Strap-On Sensor was designed to be tested in conjunction with the following specifications:

### Electrical Fast Transients:

IEC 61000-4-4:2004

### Radiated Emissions, Group 1, Class B:

CISPR 11

### Electrostatic Discharge:

IEC 61000-4-2:2002

### Radiated Immunity:

IEC 61000-4-3:2002

### Power Frequency Magnetic Fields:

Performed per IEC 60601-1-2:2004

### General Safety Requirements:

IEC 60601-1:1988

## OPTIONS

- ◆ Custom OEM designs
- ◆ Custom response times
- ◆ Open collector output
- ◆ Reverse logic output

## THREE-YEAR WARRANTY

All Introtek systems are warranted free of defects in materials or workmanship for three full years from the date of original factory shipment.

If returned within the warranty period; and, upon factory inspection of the unit, the cause of the malfunction is determined to be defective material or workmanship; then, Introtek will repair or replace the system at no cost to the purchaser (or owner) other than transportation.

Introtek shall not be liable for misapplication, labor claims, direct or consequential damage or expense arising from the installation or use of the equipment. There are no other warranties expressed or implied, except special written warranties covering some Introtek products.



Introtek International, L.P., Subsidiary of Magnetrol International, Incorporated  
150 Executive Drive • Edgewood, New York 11717-9998  
631-242-5425 • Fax 631-242-5260 • www.introtek.com • info@introtek.com

©2009 Introtek International, L.P. All rights reserved.

Printed in the USA. Magnetrol, Introtek, and Introtek logotype are registered trademarks of Magnetrol International.

Performance specifications are effective with date of issue and are subject to change without notice.