

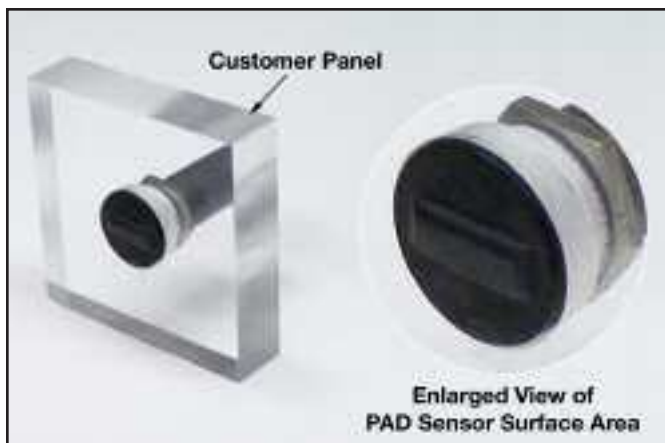

The Introtek Advantage provides products of unsurpassed quality, functionality and dependability that are manufactured to the highest medical device standards and backed by a three-year warranty.

Point-Air Detection (PAD) Sensor

The PAD Sensor delivers a reflective ultrasonic signal from a single contact point. The ultimate air detection sensor for a fluid-handling cassette application.



Introtek Point-Air Detection (PAD) Sensors incorporate the state-of-the-art, patented pulse-type ultrasonic circuitry. Integral to the sensor's assembly, the Micro-Electronic Controller (MEC) features programmable algorithms for functionality control. Response times, time delays, and other functions are programmed in accordance to specific requirements.

TECHNOLOGY

Introtek patented pulse-type ultrasound provides highly reliable, non-invasive air detection capabilities in critical applications where the safety of a patient or the integrity of a process is essential. Many of the variables which affect the accuracy of amplitude based or continuous wave ultrasound are greatly reduced if not eliminated by pulse-type technology.

HIGHLIGHTS

- ◆ Compact design features integral MEC circuitry.
- ◆ Programmable micro-controller expands the circuit's functionality.
- ◆ High EMI and RFI noise immunity.
- ◆ Reliable pulse-type, non-invasive ultrasound.
- ◆ Air detection threshold or bubble size can be set to our customer's requirements.
- ◆ Accommodates a wide range of disposable cassette assemblies that incorporate fluidic channels.
- ◆ Dry coupled; no coupling gel is required.
- ◆ Accuracy is not affected by fluid or tubing color.

INTROTEK CERTIFICATIONS



APPLICATIONS

- ◆ Air bubble, air-in-line and liquid level sensing
- ◆ Patient-connected medical devices, including:
 - Apheresis
 - Auto-transfusion
 - Infusion pumps
 - Heart-lung bypass
 - Dialysis
 - Cardiac assist pumps
 - Perfusion-based "life support" devices
- ◆ Chromatography and separations technology
- ◆ Immunoassay and diagnostic equipment
- ◆ Liquid and chemical dispensing
- ◆ Blood processing equipment

Point-Air-Detection (PAD) Sensor

SENSOR PART NUMBER

Please contact an Introtek Application Specialist to determine the optimal configuration for your application.

FUNCTIONAL SPECIFICATIONS

Supply Voltage:

5 VDC, 12 VDC or 24 VDC

Supply Current:

15 mA

Output Signal:

CMOS levels, programmable for High or Low on Wet.
Output levels to within 0.5 V of power rails with 5mA loading.

Self-test Input:

Provides an electronic check for false wet output signals.

Response Time:

Air Detection (Wet to Dry): 215 μ S typical
Liquid Detection (Dry to Wet): 46 mS typical

Operating Temperature:

+41° to +140° F (+5° to +60° C)

Humidity:

0 – 95% Non-Condensing

OPTIONS

- ◆ Reverse output logic
- ◆ Custom response times
- ◆ Custom OEM designs
- ◆ Integral or remote circuitry

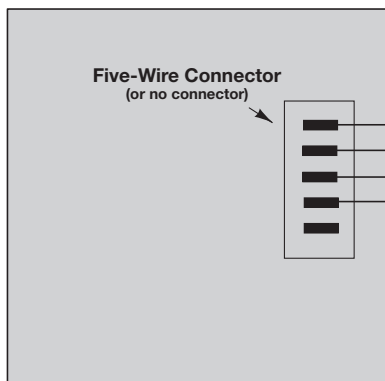
**Five-Wire Color Code
(Default Configuration)**

RED	Input DC Voltage (5.0 V)
BLACK	Ground (Return)
GREEN	Self-Test (Connect to Ground for Normal Operation)
ORANGE	CMOS Logic Output

**NOTE: Custom Assemblies and Provisions
may require other system connections**

VALIDATION TESTING

The Point-Air Detection Sensor was designed to be tested in conjunction with the following specifications:

Electrical Fast Transients:

IEC 61000-4-4:2004

Radiated Emissions, Group 1, Class B:

CISPR 11

Electrostatic Discharge:

IEC 61000-4-2:2002

Radiated Immunity:

IEC 61000-4-3:2002

Power Frequency Magnetic Fields:

Performed per IEC 60601-1-2:2004

General Safety Requirements:

IEC 60601-1:1988

THREE-YEAR WARRANTY

All Introtek systems are warranted free of defects in materials or workmanship for three full years from the date of original factory shipment.

If returned within the warranty period; and, upon factory inspection of the unit, the cause of the malfunction is determined to be defective material or workmanship; then, Introtek will repair or replace the system at no cost to the purchaser (or owner) other than transportation.

Introtek shall not be liable for misapplication, labor claims, direct or consequential damage or expense arising from the installation or use of the equipment. There are no other warranties expressed or implied, except special written warranties covering some Introtek products.



Introtek International, L.P., Subsidiary of Magnetrol International, Incorporated

150 Executive Drive • Edgewood, New York 11717-9998 • 631-242-5425 • Fax 631-242-5260
www.introtek.com • info@introtek.com

©2010 Introtek International, L.P. All rights reserved.

Printed in the USA. Magnetrol, Introtek, and Introtek logotype are registered trademarks of Magnetrol International.

Performance specifications are effective with date of issue and are subject to change without notice